



SMUV

PT. GREAT MICROTAMA ELECTRONICS INDONESIA

**2 Pad version : 11.4 x 4.8 mm**

- Recommended for automotive applications
- Reflow soldering temperature : 260°C max
- Package high 5.60 mm max



Pb free : Pins / pads

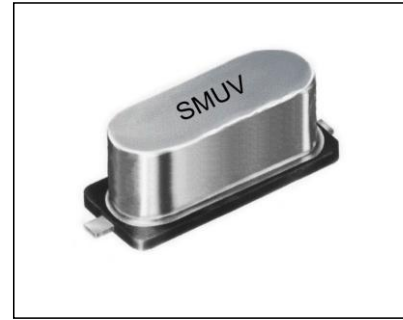

**General Specifications**

Frequency Range	3.27 ~ 40.0 MHz (Fund. AT-Cut)				
Frequency Tolerance @ 25 degC	±10 ppm ~ ±30 ppm				
Frequency Stability	±10 ppm ~ ±50 ppm				
Operating Temperature Range	Temp Range	±10ppm	±20ppm	±30ppm	±50ppm
	-20 °C to +70 °C	o	o	■	o
	-40 °C to +85 °C	o	o	o	■
	* Remarks :                    ■ Standart                    o Available				
Equivalent Series Resistance	Please refer to table 1 below				
Load Capacitance	12 pF (standard)				
Drive Level	100µW				

\* Remarks : Please contact us for any further enquiry

**Frequency Range, Equivalent Series Resistance and Mode of Oscillation (Table 1)**

Frequency Range (MHz)	Equivalent Series Resistance Maximum (Ohm)
<b>Fundamental AT Cut</b>	
3.276 ~ 3.499	200
3.579 ~ 3.999	120
4.000 ~ 5.999	80
6.000 ~ 6.999	70
7.000 ~ 8.999	50
9.000 ~ 13.999	35
14.999 ~ 40.000	30
<b>Fundamental BT Cut</b>	
30.00 ~ 50.000	50
<b>Third Overtone</b>	
24.000 ~ 150.000	on request

Specifications are subjected to change without notice.

**Dimensions**

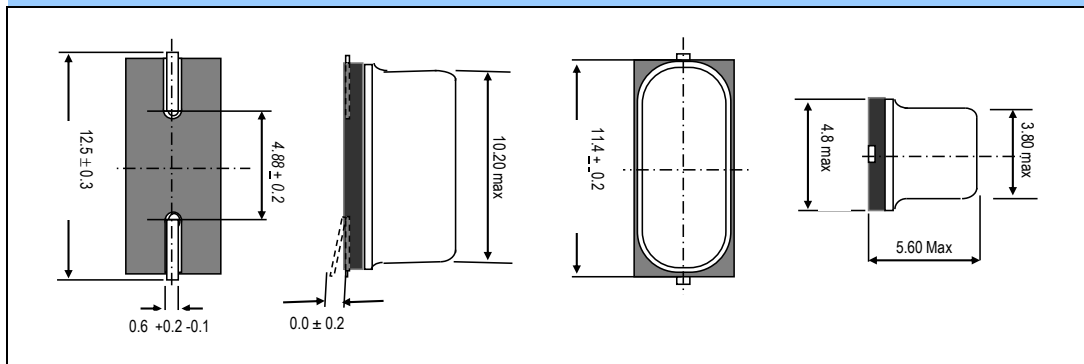

PT Great Microtama Electronics Ind. Berbek Industri III/21 Surabaya. Indonesia  
 Fax: 62-31-8431305 Tel: 62-31-8431330 E-mail: greatind@greatmicro.com